



• www.mytronic.ir



• [mytronic.ir](https://www.instagram.com/mytronic.ir)



• [mytronic_ir](https://www.telegram.com/mytronic_ir)



• [mytronicir](https://www.youtube.com/mytronicir)



• 0912-5958431
• 0912-5958432



• 021-66717001



مایترونیک

فروشگاه قطعات الکترونیک

تخصص، کیفیت، قیمت مناسب

■ Features

- Super low on-state resistance:

$R_{DS(on)1} = 125\text{m}\Omega$ MAX. ($V_{GS} = 10\text{V}$, $I_D = 8\text{A}$)

$R_{DS(on)2} = 148\text{m}\Omega$ MAX. ($V_{GS} = 4.5\text{V}$, $I_D = 8\text{A}$)

- Low C_{iss} : $C_{iss} = 900\text{pF}$ TYP.

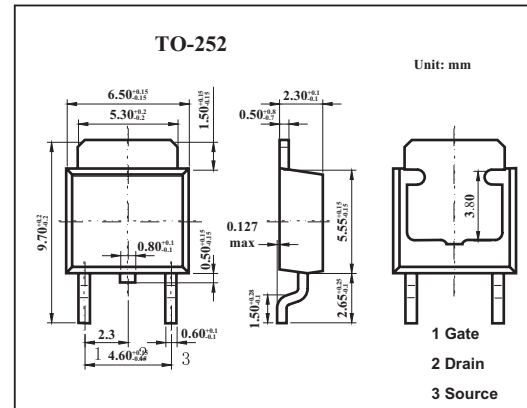

■ Absolute Maximum Ratings $T_a = 25^\circ\text{C}$

Parameter	Symbol	Rating	Unit
Drain to source voltage	V_{DS}	100	V
Gate to source voltage	V_{GS}	± 20	V
Drain current	I_D	± 16	A
	I_{DP}^*	± 22	A
Power dissipation	P_D	$T_c=25^\circ\text{C}$	30
		$T_A=25^\circ\text{C}$	1.0
Channel temperature	T_{ch}	150	$^\circ\text{C}$
Storage temperature	T_{stg}	-55 to +150	$^\circ\text{C}$

* $PW \leq 10\mu\text{s}$, Duty Cycle $\leq 1\%$

■ Electrical Characteristics $T_a = 25^\circ\text{C}$

Parameter	Symbol	Test conditions	Min	Typ	Max	Unit
Drain cut-off current	I_{DSS}	$V_{DS}=100\text{V}, V_{GS}=0$			10	μA
Gate leakage current	I_{GSS}	$V_{GS}=\pm 20\text{V}, V_{DS}=0$			± 10	μA
Gate cutoff voltage	$V_{GS(off)}$	$V_{DS}=10\text{V}, I_D=1\text{mA}$	1.5	2.0	2.5	V
Forward transfer admittance	$ Y_{fs} $	$V_{DS}=10\text{V}, I_D=8\text{A}$	4.5	9.5		S
Drain to source on-state resistance	$R_{DS(on)1}$	$V_{GS}=10\text{V}, I_D=8\text{A}$		100	125	$\text{m}\Omega$
	$R_{DS(on)2}$	$V_{GS}=4.5\text{V}, I_D=8\text{A}$		110	148	$\text{m}\Omega$
Input capacitance	C_{iss}	$V_{DS}=10\text{V}, V_{GS}=0, f=1\text{MHz}$		900		pF
Output capacitance	C_{oss}			110		pF
Reverse transfer capacitance	C_{rss}			50		pF
Turn-on delay time	t_{on}	$I_D=8\text{A}, V_{GS(on)}=10\text{V}, R_G=0\Omega, V_{DD}=50\text{V}$		9.0		ns
Rise time	t_r			5.0		ns
Turn-off delay time	t_{off}			30		ns
Fall time	t_f			4.0		ns
Total Gate Charge	Q_G		$I_D=16\text{A}, V_{DD}=80\text{V}, V_{GS}=10\text{V}$		20	
Gate to Source Charge	Q_{GS}			3.0		nC
Gate to Drain Charge	Q_{GD}			5.0		nC